

# INSTALLATION INSTRUCTIONS

## Please Note Before Installation

Hardware Resource Company (HRC) cannot control the use or installation of add-on, spare, or replacement parts. Therefore, HRC shall have no responsibility for injury or damage resulting from improper installation or other misuse. Parties undertaking use of these parts assume full responsibility for following proper installation procedures.

## Instructions for installing replacement connecting hardware kits.

- 1.) Ensure all electrical power and voltage has been turned off, locked off, and tagged out. Do not attempt to install product into a switchboard or panelboard while energized. Installation of this product should be performed by qualified personnel only.
- 2.) After electricity has been locked off and tagged out, confirm that no electrical current is present by using a calibrated voltage detection instrument.
- 3.) Remove dead front cover plates as necessary to gain access to work area.
- 4.) De-energized bus bar should now be exposed. Install the B phase (center phase) connector first. Tighten screws or bolts to finger tight at this point.
- 5.) Install out side phase connector(s), and tighten with fingers.
- 6.) Install bus bar anti-turn devices if provided. (Not all kits utilize anti-turn devices.)
- 7.) Install circuit breaker or switch mounting brackets if provided.
- 8.) If available, place the circuit breaker or switch into its intended location to verify proper alignment and fit. If not available, refer to the attached assembly drawings for proper dimensions and locations of components parts. (Circuit breaker or switch is not included in this kit.)
- 9.) After proper alignment has been verified, tighten all bus connections with a calibrated torque wrench to the values listed in table to the right. Check to be sure there are no visible obstructions or foreign materials present that might reduce proper electrical clearances, or damage insulated conductors. Remove any obstructions or foreign materials before continuing.
- 10.) If available, install circuit breaker or switch onto connectors. If not available, go to step 11.
- 11.) Install circuit breaker or switch filler plates when provided. (Some may not be required with twin-mounted breakers)
- 12.) Re-install dead front cover plates. Do not re-energize the switchboard or panelboard without first following all safety and procedural practices necessary to ensure it is safe to re-apply power to the equipment. Only qualified personnel shall re-energize any switchboard or panel board.

Torque Values for Copper or Aluminum Bar Connections		
Bolt Size Inch, (mm)		Torque lb, - in.
#10		30
1/4	(6.4)	65
5/16	(7.9)	128
3/8	(9.5)	240
1/2	(12.7)	600

**NOTICE**

THE USE OF THE ORIGINAL EQUIPMENT MANUFACTURER'S TRADEMARK IS FOR INFORMATIONAL PURPOSES ONLY AND DOES NOT REPRESENT AN ENDORSEMENT OF THIS PRODUCT BY THE MANUFACTURER.

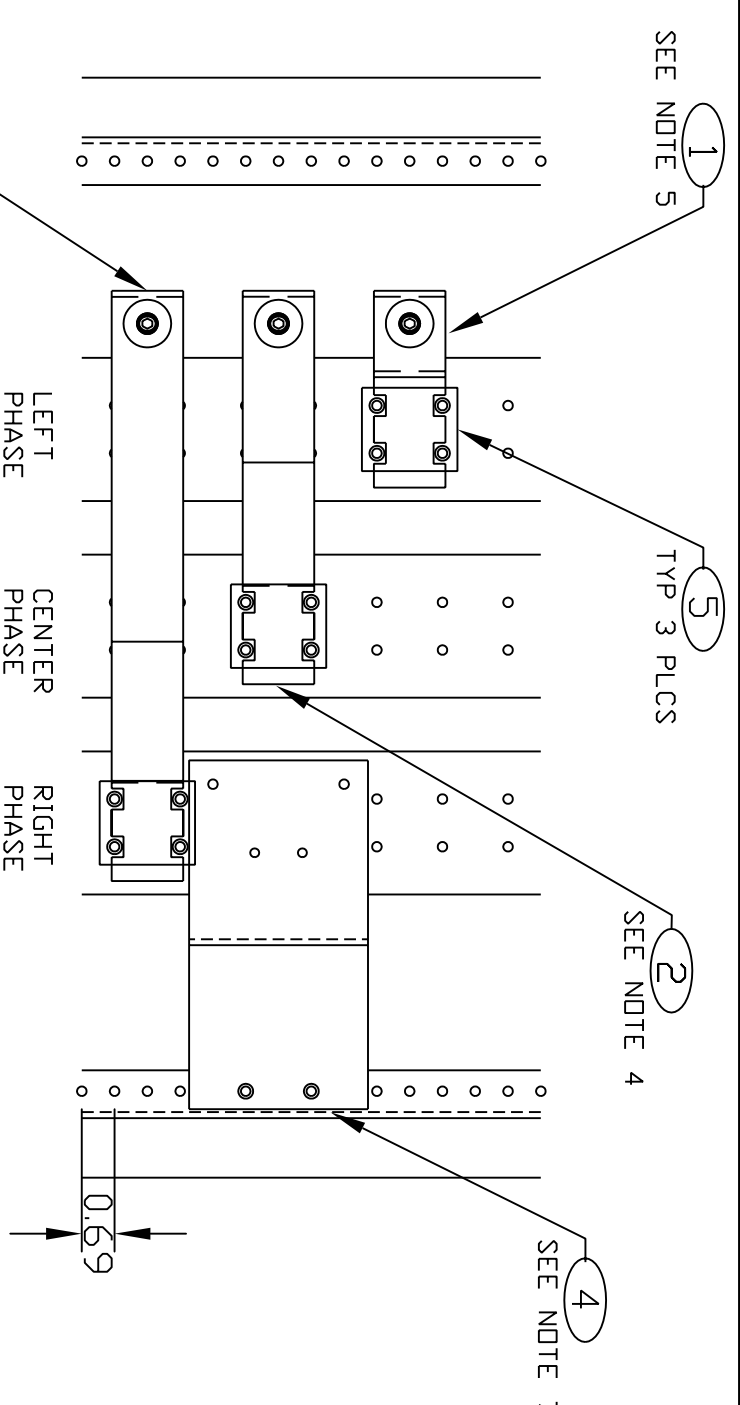

FRONT VIEW SHOWING MOUNTING LOCATIONS OF CONNECTIONS TO BUS BARS AND BREAKER MOUNTING BRACKET TO "Z" RAILS (BREAKER REMOVED TO SHOW CONNECTORS)

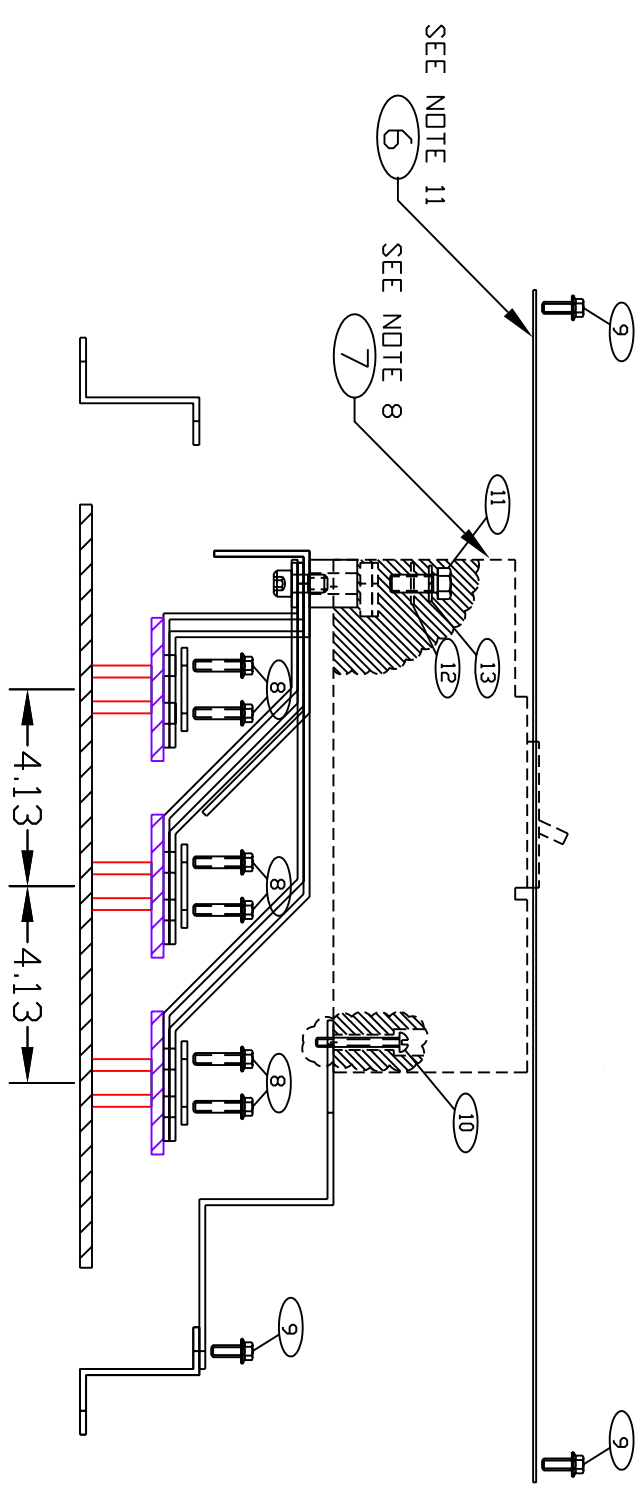

ITEM	QTY	DESCRIPTION	DWG No.
1	1	A PHASE CONNECTOR	21J-A171LD4-01-01
2	1	B PHASE CONNECTOR	21J-A171LD4-01-02
3	1	C PHASE CONNECTOR	21J-A171LD4-01-03
4	1	BREAKER MOUNTING BRACKET	21M-A171LD4-00-04
5	3	BRANCH BUS SUPPRT	21S-A109-01
6	1	DEAD FRONT/FILLER PLATE	21F-A171LD4-00-06
7	12	BREAKER DR SWITCH	
8	4	1/4-20 X 1/4" SELF TAP BOLT	
9	2	1/4-20 X 3/8" SELF TAP BOLT	
10	4	1/4-20 X 1 1/2" ROUND HD SCREW	
11	3	3/8-16 X 1000" HEX CAP SCREW	21H-A171LD4-01
12	3	3/8" FLAT WASHER	
13	3	3/8" SPLIT LOCK WASHER	



TITLE: CUTLER-HAMMER/WESTINGHOUSE 600AMP MOUNTING HARDWARE FOR LD, HLD, LDC BREAKERS IN\_PRL-4 TYPE PANEL SINGLE MTD

DRAWING No.	LAYER
21-A1-LD4	LD4
KIT No. 21-A171LD4	REV D

REV	DATE	BY	DESCRIPTION
REV-D	01-07-04	AA	SCREW SIZE ITEM 8
REV-C	12-5-03	FG	DWG NO ITEM 1, 2, 3
REV-B	7-1-03	AA	REV'D DWG NO ITEM 5
REV-A	9-5-02	AA	ADDED ITEM 13.

REV	DATE	BY	DESCRIPTION
REV-D	01-07-04	AA	SCREW SIZE ITEM 8
REV-C	12-5-03	FG	DWG NO ITEM 1, 2, 3
REV-B	7-1-03	AA	REV'D DWG NO ITEM 5
REV-A	9-5-02	AA	ADDED ITEM 13.